

Features

- 12:1 Wide Input Range
- Operating Temperature Range: -40~105°C
- Approved to cURus, UKCA, CE, ROHS & REACH
- Safety Standards to IEC/UL/EN62368-1 & EN50155
- Efficiency up to 91%
- EMC Class A & B
- Single 40W Output Models
- Available with optional heatsink (HS)



Ideal Power's 43QAE40-xSyU 40W Series Quarter Brick DC/DC Converters are certified to cURus, UKCA, CE, RoHS, REACH & IEC/UL/EN 62368-1, EN 50155 Standards and comply with the relevant Efficiency Regulations. These are primarily used in ITE, Video & Audio, Railway Industries and customised solutions are available upon request.

Part Number Structure

43QAE40-	72	S	05	U	K	-	P	HS
Series Name	Input Voltage (VDC)	Output Quantity	Output Voltage (VDC)	Input Range	Pin Connection Options		Remote On/Off Options	Assembly Options
	36: 9 ~ 75 75: 14 ~ 160	S: Single	05: 5 12: 12 15: 15 24: 24 28: 28 48: 48 53: 53	8:1 12:1	<input type="checkbox"/> : None K: With Bus & UVP adj. V: With UVP adj.		<input type="checkbox"/> : Negative logic P: Positive logic	<input type="checkbox"/> : None Heat-sink type HS1: 7GA0127P01-F; H=0.65" HS2: 7GA0128P01-F; H=1" HS3: 7G-0032B-F; H=0.5" HS4: 7GA0124P01-F; H=0.65" HS5: 7GA0125P01-F; H=1" Through hole type TH: No thread* *The module can't equip Heat-sink with TH option.

Models

Model Number	Input Range	Output Voltage	Output Current @Full Load mA	Input Current @No Load mA	Efficiency %	Maximum Capacitor Load μF
43QAE40-36S05U	9 ~ 75	5	8	20	89	16000
43QAE40-36S12U	9 ~ 75	12	3.33	30	91	2800
43QAE40-36S15U	9 ~ 75	15	2.67	30	91	1800
43QAE40-36S24U	9 ~ 75	24	1.67	20	90	720
43QAE40-36S28U	9 ~ 75	28	1.43	20	91	520
43QAE40-36S48U	9 ~ 75	48	0.83	20	91	180
43QAE40-36S53U	9 ~ 75	53	0.75	20	91	150
43QAE40-72S05U	14 ~ 160	5	8	15	89	16000
43QAE40-72S12U	14 ~ 160	12	3.33	20	91	2800
43QAE40-72S15U	14 ~ 160	15	2.67	20	91	1800
43QAE40-72S24U	14 ~ 160	24	1.67	15	90	720
43QAE40-72S28U	14 ~ 160	28	1.43	15	91	520
43QAE40-72S48U	14 ~ 160	48	0.83	15	90	180
43QAE40-72S53U	14 ~ 160	53	0.75	15	91	150

Input Specifications

Parameter	Conditions	Min	Typ	Max	Unit
Operating input voltage range	36Vin(nom)	9	36	75	VDC
	72Vin(nom)	14	72	160	
Start-up voltage	36Vin(nom)	--	--	9	VDC
	72Vin(nom)	--	--	14	
Shutdown voltage	36Vin(nom)	7.3	7.7	8.1	VDC
	72Vin(nom)	10	11	12	
Start-up time	Constant resistive load Power up Remote ON/OFF	--	75	100	ms
		--	75	100	
Input Transient voltage	100 mS, max.	36Vin(nom)	8.1	--	VDC
		72Vin(nom)	12	--	
Input surge voltage	1 second, max.	36Vin(nom)	--	100	VDC
		72Vin(nom)	--	185	
(1) Input filter	Pi type				
Remote ON/OFF	Referred to -Vin pin	Negative logic	DC-DC ON	Short or 0 ~ 1.2VDC	
		(Standard)	DC-DC OFF	Open or 3 ~ 12VDC	
		Positive logic	DC-DC ON	Open or 3 ~ 12VDC	
		(Option)	DC-DC OFF	Short or 0 ~ 1.2VDC	
		Input current of Ctrl pin	-0.5	--	1 mA
		Remote off input current	--	3	-- mA

Output Specifications

Parameter	Conditions	Min	Typ	Max	Unit
Voltage accuracy		-1.0	--	+1.0	%
Line regulation	Low Line to High Line at Full Load	-0.1	--	+0.1	%
Load regulation	No Load to Full Load	-0.1	--	+0.1	%
Voltage adjustability	Maximum output deviation is inclusive of remote sense	-20	--	+10	%
Remote sense	% Of Vout(nom). If remote sense is not being used, SENSE pins should connect to corresponding polarity OUTPUT pins.	--	--	10	%
Ripple and noise	Measured by 20MHz bandwidth				
	With a 1 μ F/25V X7R MLCC and a 22 μ F/25V POS-CAP	5Vout	--	75	--
	With a 22 μ F/25V X7R MLCC	12Vout, 15Vout	--	100	--
	With a 4.7 μ F/50V X7R MLCC	24Vout, 28Vout	--	200	--
	With a 2.2 μ F/100V X7R MLCC	48Vout, 53Vout	--	300	--
Temperature coefficient		-0.02	--	+0.02	%/°C
Transient response recovery time	25% load step change	--	250	--	μ s
Over voltage protection	% of Vout(nom); Hiccup mode	120	--	135	%
Overload protection	% of Iout rated; Hiccup mode	120	--	140	%
Short circuit protection		Continuous, automatic recovery			

General Specifications

Parameter	Conditions	Min	Typ	Max	Unit
Isolation voltage	1 minute (Reinforced insulation)	72Vin(nom)	Input to Output	3000	--
			Input (Output) to Baseplate	1500	--
	1 minute (Basic insulation)	36Vin(nom)	Input to Output	2250	--
			Input (Output) to Baseplate	1600	--
Isolation resistance	500VDC	1	--	--	G Ω
Isolation capacitance		--	--	1000	pF
Switching frequency		160	180	200	kHz
Safety approvals	IEC/ EN/ UL62368-1				UL:E193009 CB:UL(Demko)
Standard approvals	EN50155 EN45545-2				
Case material		Aluminum baseplate with plastic case			
Potting material		Silicone (UL94 V-0)			
Weight		64g (2.26oz)			
MTBF	MIL-HDBK-217F, Full load	8.297 x 10 ⁵ hrs			

Environmental Specifications

Parameter	Conditions	Min	Typ	Max	Unit
Operating base-plate temperature		-40	--	+10	°C
Maximum case temperature		--	--	105	°C
Over temperature protection		--	110	--	°C
Storage temperature range		-55	--	+12	°C
Thermal impedance	Module without assembly option	--	8.3	--	°C/W
	Only mount on the iron base-plate	--	2.5	--	
	Heat-sink type with 0.24" Height	--	7.4	--	
	Heat-sink type with 0.5" Height	--	6.2	--	
	Heat-sink type with 0.65" Height	--	5.1	--	
	Heat-sink type with 1" Height	--	4.1	--	
Thermal shock					MIL-STD-810F
Vibration					MIL-STD-810F
Relative humidity					5% to 95% RH

EMC Specifications

Parameter	Conditions	Level
EMI	EN55032, EN50121-3-2 With external components	Class A, Class B
EMS	EN55024, EN50121-3-2	
ESD	EN61000-4-2 Air ± 8kV and Contact ± 6kV	Perf. Criteria A
Radiated immunity	EN61000-4-3 20 V/m	Perf. Criteria A
Fast transient	EN61000-4-4 ± 2kV	Perf. Criteria A
	43QAE40-36S□□U With 2 pcs of aluminum electrolytic capacitor (Nippon Chemi-Con KY series, 220µF/100V)	
	43QAE40-72S□□U With 2 pcs of aluminum electrolytic capacitor (Nippon Chemi-Con KXJ series, 150µF/200V)	
Surge	EN61000-4-5 EN55024:±1kV and EN50155:±2kV	Perf. Criteria A
	43QAE40-36S□□U With 2 pcs of aluminum electrolytic capacitor (Nippon Chemi-con KY series, 220µF/100V)	
	43QAE40-72S□□U With 2 pcs of aluminum electrolytic capacitor (Nippon Chemi-con KXJ series, 150µF/200V)	
Conducted immunity	EN61000-4-6 10 Vr.m.s	Perf. Criteria A
Power frequency magnetic field	EN61000-4-8 100A/m continuous; 1000A/m 1 second	Perf. Criteria A

Note:

1. Input source impedance: The power module will operate as specifications without external components, assuming that the source voltage has a very low impedance and reasonable input voltage regulation. Highly inductive source impedances can affect the stability of the power module. Since real-world voltage source has finite impedance, performance can be improved by adding external filter capacitor.

The 43QAE60-36S□□U recommended Nippon Chemi-con KY series, 220µF/100V.

The 43QAE60-72S□□U recommended Nippon Chemi-con KXJ series, 150µF/200V.

2. BASE-PLATE GROUNDING: When connect two screw bolts to shield plane, the EMI could be reduced.

CAUTION: This power module is not internally fused. An input line fuse must always be used.

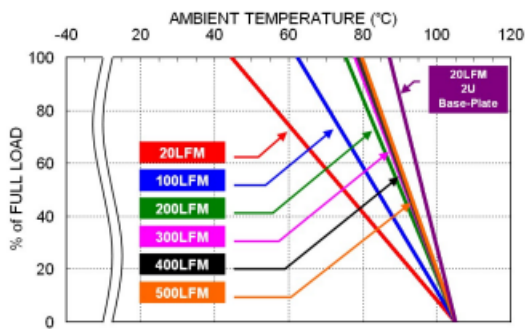
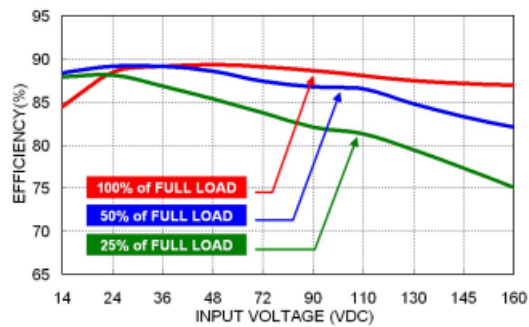
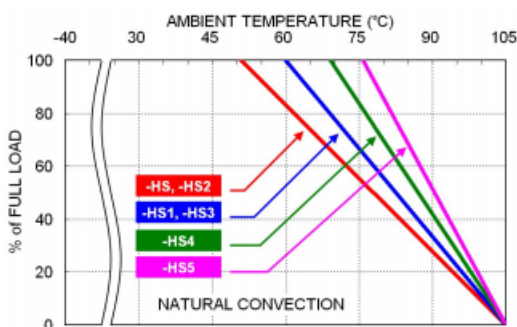
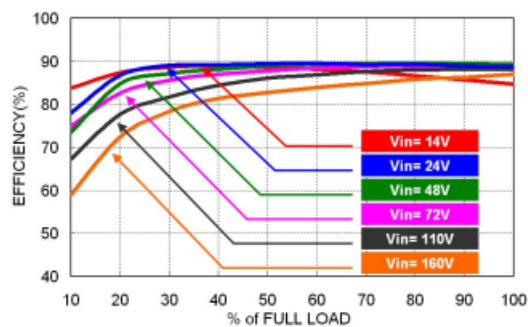
Characteristic Curve

 43QAE40-72S05U Derating Curve
 (See Thermal Considerations)

 43QAE40-72S05U Efficiency vs. Input
 Voltage

 43QAE40-72S05U Derating Curve with Heat-sink
 (See Thermal Considerations)

43QAE40-72S05U Efficiency vs. Output Load

Fuse Consideration

This power module is not internally fused. An input line fuse must always be used. This encapsulated power module can be used in a wide variety of applications, ranging from simple stand-alone operation to an integrated part of sophisticated power architecture. To maximum flexibility, internal fusing is not included; however, to achieve maximum safety and system protection, always use an input line fuse.

The input line fuse suggest as below :

Model	Fuse Rating (A)	Fuse Type
43QAE40-36S□□U	8	Fast-Acting
43QAE40-72S□□U	5	Slow-Blow

The table based on the information provided in this data sheet on inrush energy and maximum DC input current at low Vin.

Mechanical Drawing

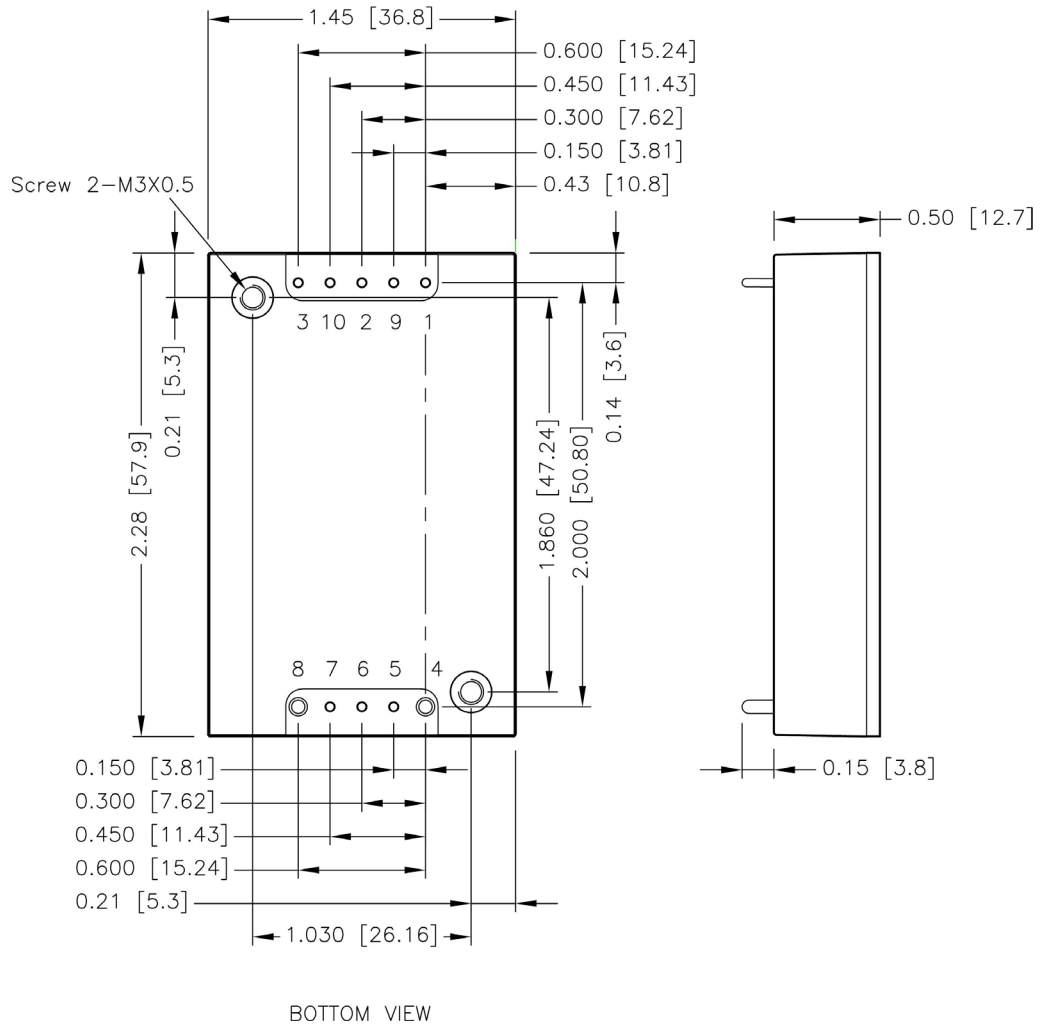

PIN	DEFINE	DIAMETER
1	- Vin	0.04 Inch
2	Ctrl	0.04 Inch
3	+ Vin	0.04 Inch
4	- Vout	0.06 Inch
5	- Sense	0.04 Inch
6	Trim	0.04 Inch
7	+ Sense	0.04 Inch
8	+ Vout	0.06 Inch
9	Bus	0.04 Inch
10	UVLO	0.04 Inch

Recommended Pad Layout

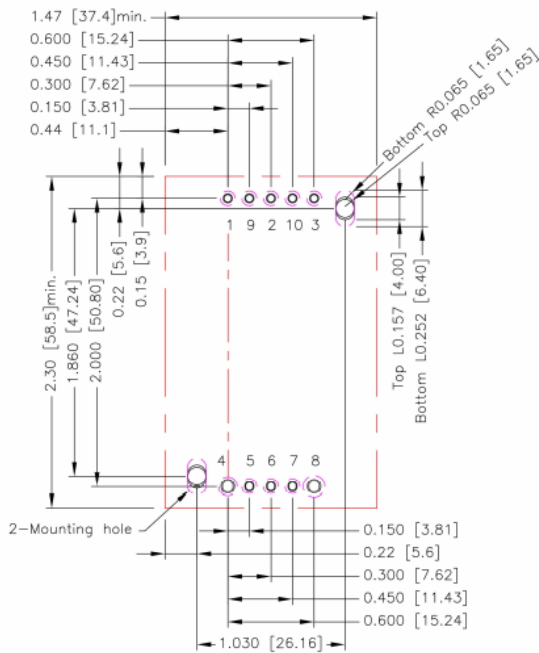

All dimensions in inch[mm]
 Pad size(lead free recommended)
 Through hole 1.2.3.5.6.7.9.10:Ø0.051[1.30]
 Through hole 4.8:Ø0.075[1.90]
 Through hole of mounting:Ø0.126[3.20]
 Top view pad 1.2.3.5.6.7.9.10:Ø0.064[1.63]
 Top view pad 4.8:Ø0.094[2.38]
 Top view pad of mounting:Groove R0.065[1.65]L0.157[4.00]
 Bottom view pad 1.2.3.5.6.7.9.10:Ø0.102[2.60]
 Bottom view pad 8:Ø0.150[3.80]
 Bottom view pad 4:Ø0.130[3.30]
 Bottom view pad of mounting:Groove R0.065[1.65]L0.252[6.40]

Thermal Considerations

The power module operates in a variety of thermal environments. However, sufficient cooling should be provided to help ensure reliable operation of the unit. Heat is removed by conduction, convection, and radiation to the surrounding Environment. Proper cooling can be verified by measuring the point as the figure below. The temperature at this location should not exceed "Maximum case temperature". When operating, adequate cooling must be provided to maintain the test point temperature at or below "Maximum case temperature". You can limit this Temperature to a lower value for extremely high reliability.

- Thermal test condition with vertical direction by natural convection (20LFM).
- The iron base-plate dimension is 19" X 3.5" X 0.063" (The height is EIA standard 2U).
- The heat-sink is optional and P/N: 7G-0029B-F, 7G-0030B-F, 7G-0031B-F, 7G-0032B-F, 7GA0124P01-F, 7GA0125P01-F

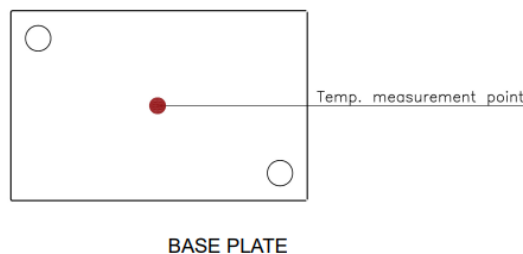

Heat-Sink Type Options

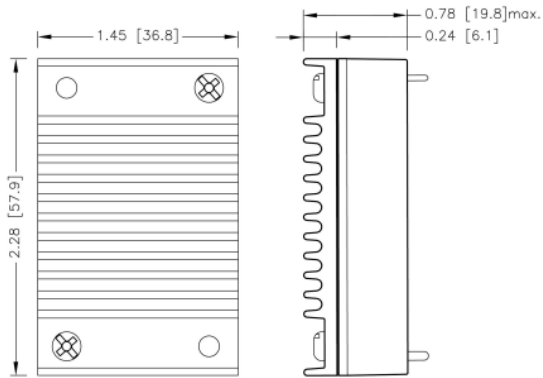
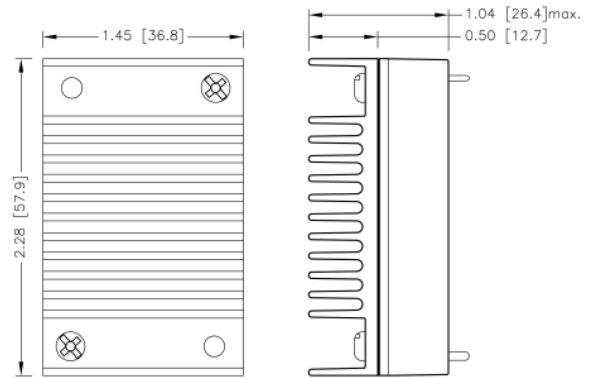
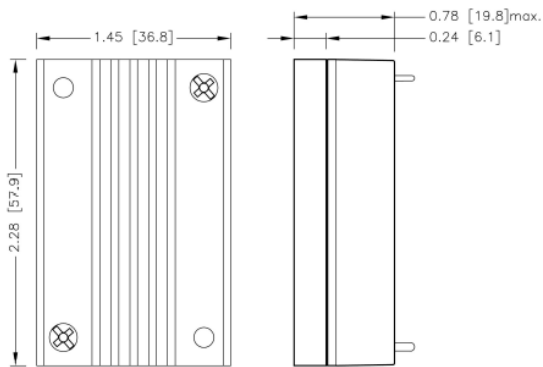
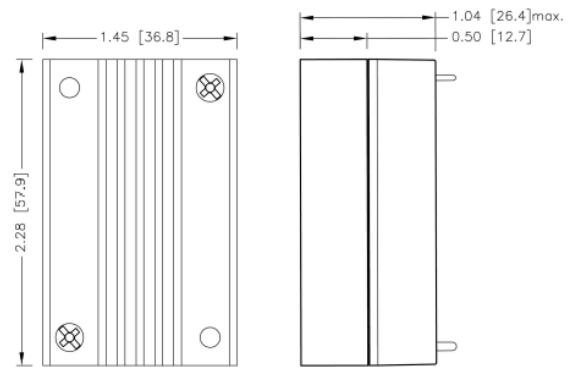
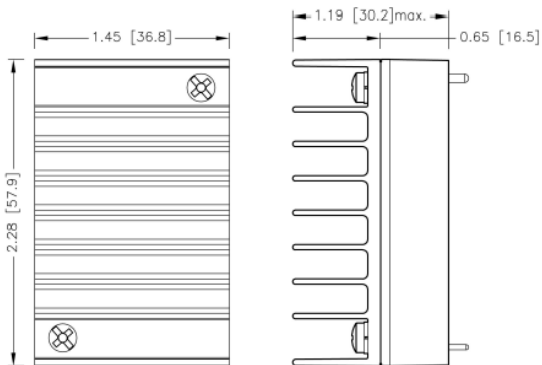
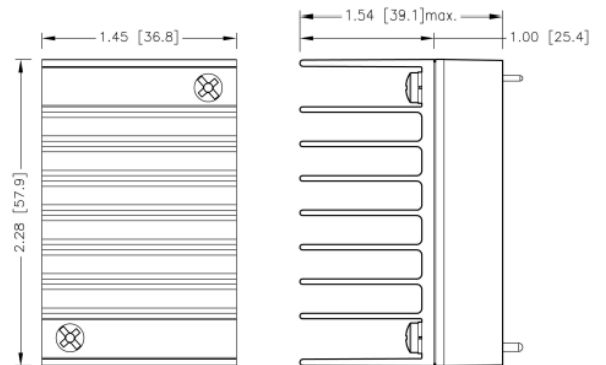
 43QAE40-□□S□□0U –HS
 7G-0029B-F

 43QAE40-□□S□□U –HS1
 7G-0030B-F

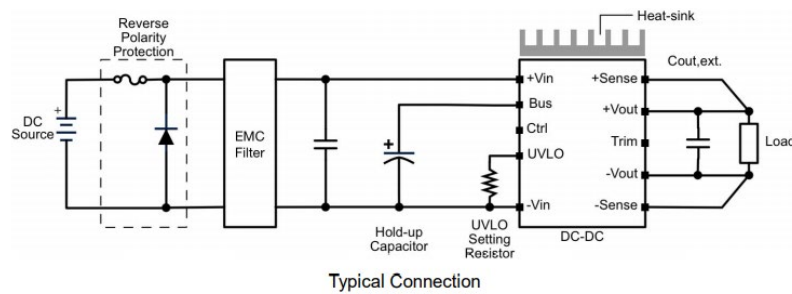
 43QAE40-□□S□□U –HS2
 7G-0031B-F

 43QAE40-□□S□□U –HS3
 7G-0032B-F

 43QAE40-□□S□□U –HS4
 7GA0124P01-F

 43QAE40-□□S□□U –HS5
 7GA0125P01-F

1. All dimensions in inch [mm]
2. Tolerance :x.xx±0.02 [x.x±0.5]

Typical Application

UVLO

This series product has ultra-wide input range. It could cover many kinds of nominal input voltage in one module. To preventing incorrect operating under different input system, it offers UVLO adjustment by connecting a resistor to set UVLO threshold.

UVLO Constants

Model	A	B	C
43QAE40-36S00U	48000	8273	0.96
43QAE40-72S00U	120000	12500	2.4

UVLO Equation

Start-up Voltage

$$V_{\text{start-up}} = 1.25 \times \left[\frac{A \times (R_{\text{UVLO}} + B)}{R_{\text{UVLO}} \times B} + 1 \right]$$

Shutdown Voltage

$$V_{\text{shutdown}} = V_{\text{start-up}} - C$$

UVLO values for various nominal input voltage and RUVLO table
43QAE40-36S00U

Nominal Vin	12V	24V	36V	48V
Start-up voltage	8.46V	13.36V	20.56V	27.76V
Shutdown voltage	7.5V	12.4V	19.6V	26.8V
UVLO Setting resistor	Open	12.35 KΩ	4.98 KΩ	3.12 KΩ

43QAE40-72S00U

Nominal Vin	24V	36V	48V	72V	96V	110V
Start-up voltage	14.8V	22V	29.2V	43.6V	58V	66.4V
Shutdown voltage	12.4V	19.6V	26.8V	41.2V	55.6V	64V
UVLO Setting resistor	96.77 KΩ	17.14 KΩ	9.40 KΩ	4.94 KΩ	3.35 KΩ	2.82 KΩ

Hold Up Time

Generally, connecting many hold up capacitors on input are necessary to get a long duration of hold up time for S2, C2 described in EN50155. The Bus pin features excellent function can simply connect capacitors to Bus pin with less quantity of capacitors. It helps reduce layout area and smooth the inrush current. For further information, please contact P-DUKE.

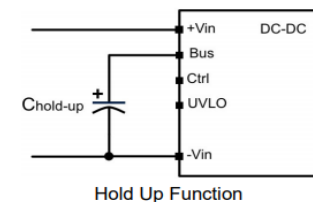
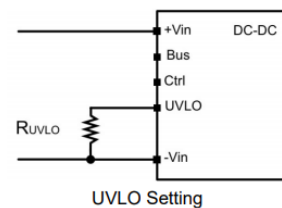

Output Voltage Adjustment

Output voltage is adjustable for 10% trim up or -20% trim down of nominal output voltage by connecting an external resistor between the Trim pin and either the +Sense or -Sense pins. With an external resistor between the Trim and -Sense pin, the output voltage set point decreases. With an external resistor between the Trim and +Sense pin, the output voltage set point increases. Maximum output deviation is +10% inclusive of remote sense. The external TRIM resistor needs to be at least 1/8W of rated power.

Trim Up Equation

$$R_U = \left(\frac{5.11V_{OUT}(100 + \Delta\%)}{1.225\Delta\%} - \frac{511 + 10.22\Delta\%}{\Delta\%} \right) k\Omega$$

Trim Down Equation

$$R_D = \left(\frac{511}{\Delta\%} - 10.22 \right) k\Omega$$

EXTERNAL OUTPUT TRIMMING

Output can be externally trimmed by using the method shown below.

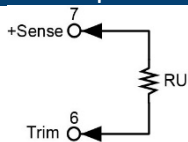
Trim Up

□□S05U

ΔV (%)	1	2	3	4	5	6	7	8	9	10
Vout (V)	5.05	5.10	5.15	5.20	5.25	5.30	5.35	5.40	5.45	5.50
RU (kΩ)	1585.35	797.994	535.542	404.316	325.58	273.09	235.596	207.476	185.605	168.109

□□S12U

ΔV (%)	1	2	3	4	5	6	7	8	9	10
Vout (V)	12.12	12.24	12.36	12.48	12.60	12.72	12.84	12.96	13.08	13.20
RU (kΩ)	4534.55	2287.19	1538.08	1163.52	938.78	788.956	681.939	601.676	539.25	489.309

□□S15U

ΔV (%)	1	2	3	4	5	6	7	8	9	10
Vout (V)	15.15	15.30	15.45	15.60	15.75	15.90	16.05	16.20	16.35	16.50
RU (kΩ)	5798.49	2925.42	1967.73	1488.89	1201.58	1010.04	873.229	770.619	690.812	626.966

□□S24U

ΔV (%)	1	2	3	4	5	6	7	8	9	10
Vout (V)	24.24	24.48	24.72	24.96	25.20	25.44	25.68	25.92	26.16	26.40
RU (kΩ)	9590.32	4840.11	3256.7	2465	1989.98	1673.3	1447.1	1277.45	1145.5	1039.94

□□S28U

ΔV (%)	1	2	3	4	5	6	7	8	9	10
Vout (V)	28.28	28.56	28.84	29.12	29.40	29.68	29.96	30.24	30.52	30.80
RU (kΩ)	11275.58	5691.08	3829.58	2898.83	2340.38	1968.08	1702.151	1502.705	1347.58	1223.48

□□S48U

ΔV (%)	1	2	3	4	5	6	7	8	9	10
Vout (V)	48.48	48.96	49.44	49.92	50.40	50.88	51.36	51.84	52.32	52.80
RU (kΩ)	19701.9	9945.94	6693.96	5067.97	4092.38	3441.99	2977.42	2628.99	2357.99	2141.19

□□S53U

ΔV (%)	1	2	3	4	5	6	7	8	9	10
Vout (V)	53.53	54.06	54.59	55.12	55.65	56.18	56.71	57.24	57.77	58.30
RU (kΩ)	21808.437	11009.651	7410.056	5610.259	4530.38	3810.461	3296.233	2910.562	2610.596	2370.623

Ideal Power Limited

14 Larks Way, Tree Beech Enterprise Park, Gunn, Barnstaple, Devon, England, EX32 7NZ.

www.idealpower.co.uk | +44 (0) 845 260 3400

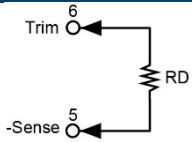
Trim Down

□□S□□U

ΔV (%)	1	2	3	4	5	6	7	8	9	10
RD (k Ω)	500.78	245.28	160.113	117.53	91.98	74.947	62.78	53.655	46.558	40.88
ΔV (%)	11	12	13	14	15	16	17	18	19	20
RD (k Ω)	36.235	32.363	29.088	26.28	23.847	21.718	19.839	18.169	16.675	15.33